



# Cargo Tank Coatings

## Recommended Working Procedures



## Introduction

Successful in service performance of cargo tank coating systems depends not only on the correct choice of coating but also on the procedures adopted for surface preparation and paint application. This document is designed to assist ship operators, shipyards and contractors achieve the optimum preparation and application standards so maximising the performance of cargo tank coatings.

## Tank Condition - Pre Contract

Prior to the commencement of abrasive blasting, it is essential that the tanks are clean, dry and in a condition suitable for the surface preparation and application of tank coatings. The points listed below briefly outline the minimum requirements:



*Chemical cargo tanks can be complex structures.*



*Chemical tankers are sophisticated ships.*

## Newbuilding

- All grease and oil must be removed from all surfaces.
- All hot work in way of tanks must be complete.
- Heating coils (if to be fitted) should be installed and masked.
- All cargo lines should be fitted and tested.
- Cargo suction strums (if fitted) should be removed in order to give total access.
- After final tank testing, tanks must be fresh water washed and dried, especially if they have been in contact with seawater.
- Prior to contract commencement, steelwork must be prepared in the manner described under "Steelwork Preparation".

## Maintenance and Repair

- Tanks must be cleaned and gas free.
- Any blisters present must be burst and blister caps removed from the surface.
- Heavy scale must be removed from all surfaces.
- Scale, debris and cargo residues must be removed from the tanks.
- All grease and oil must be removed from all surfaces.
- All hot work in way of tanks must be complete.
- Cargo suction strums (if fitted) should be removed in order to give total access.
- All tanks must be fresh water washed.
- Any areas of steel renewal should be prepared in the manner described under "Steelwork Preparation".

Heating coils should be masked during blasting and coating.



### Steelwork Preparation

In order to provide surfaces which will ensure optimum coating performance, the following minimum steelwork preparation should be carried out:

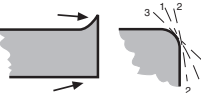
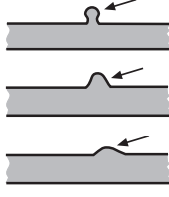
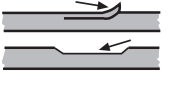
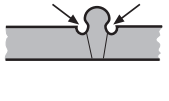
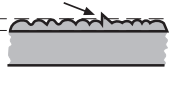
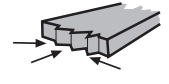
Item	Problem/Solution
<b>Sharp Edges</b>	<ul style="list-style-type: none"> <li>Remove sharp edges with grinder or disc sander.</li> </ul> 
<b>Weld Spatter</b>	<ul style="list-style-type: none"> <li>Remove weld spatter before blasting, by grinder, chipping hammer etc.</li> <li>For weld spatter observed after blasting:               <ol style="list-style-type: none"> <li>Remove with chipping hammer/scrapper, etc.</li> <li>Where weld spatter is sharp, use disc sander and grinder until obtuse.</li> <li>Obtuse weld spatter - no treatment required.</li> </ol> </li> </ul> 
<b>Plate Lamination</b>	<ul style="list-style-type: none"> <li>Plate laminations to be removed by grinder or disc sander.</li> </ul> 
<b>Undercut</b>	<ul style="list-style-type: none"> <li>Where the undercut is to a depth exceeding 1mm and a width less than the depth, repair by welding or grinding may be necessary.</li> </ul> 
<b>Manual Welds</b>	<ul style="list-style-type: none"> <li>For welding beads with surface irregularities and sharp edges, remove by disc sander or grinder.</li> </ul> 
<b>Gas Cut Surface</b>	<ul style="list-style-type: none"> <li>For surfaces and edges of excessive irregularity, remove by disc sander or grinder.</li> </ul> 

“Successful in service performance of cargo tank coating systems depends not only on the correct choice of coating but also on the procedures adopted for surface preparation and paint application.”

### Surface Preparation

Two main universal standards of surface preparation are normally specified for cargo tank coatings – ISO Standard ISO 8501-1 (1988) - Sa2<sup>1/2</sup> and Sa3.

However, in general, the following comments apply to these standards:

Sa2<sup>1/2</sup> – in practice, this is considered to be the best standard a skilled blasting operative can consistently achieve.

Sa3 – the possibility of achieving a uniform standard of Sa3 throughout the tanks is remote and a more realistic achievement would be somewhere between Sa2<sup>1/2</sup> and Sa3.

### Comparative Standards

ISO 8501-1: 1988	Japanese (JSRA) Standard on New Steel	SSPC Standard
Sa2 <sup>1/2</sup>	JA SH2	SSPC-SP10
Sa3	JA SH3	SSPC-SP5

In cases where the substrate is corroded or pitted, it may be necessary to fresh water wash affected areas after abrasive blasting, then re-blast, in order to ensure removal of soluble corrosion products.

### Compressed Air

Air used for abrasive blasting must be clean, oil-free and dry.

The pressure should be at least 7kg/cm<sup>2</sup> (100 p.s.i.) at the nozzle.

### Abrasive

Abrasives used for blasting should be clean, dry and free from dirt, oil, grease, organic or water soluble matter. Consult International Paint for recommendations on suitable abrasive material.

### Surface Profile

The surface profile required will depend upon the type of coating to be applied. Measurement on site should be by profile gauge or other instrument agreed by all parties prior to commencing surface preparation.

## Scaffolding (Staging)

### Type

Staging should be designed to allow thorough cleaning and acceptable substrate access. International Paint recommend that staging should be the 'turn over' type, when local safety regulations permit. Tubular scaffolding should not mask surfaces to be coated. Where contact with surfaces is necessary, spade ends should be used.

Tubular scaffolding should be plugged or capped prior to abrasive blasting to prevent ingress of grit and dirt (which may be subsequently dislodged, leading to coating contamination).

### Layout

Staging should afford easy and safe access to all surfaces to be coated, but should be at least 150mm to 300mm (6" to 12") from vertical surfaces to be coated.

Distance between staging levels should not exceed two metres (6.5 feet) and the staging layout should be such that ventilation is not restricted.

Care should be taken when removing scaffolding in order to minimise damage to a freshly applied coating. All coating damages should be repaired in accordance with the recommendations of the International Paint Representative on site.

### Cargo Lines

The internal areas of cargo pipe lines should be coated, if required, prior to fitting on the vessel. The external areas of cargo pipe lines should be blasted and coated at the same time as the lowermost 2 metres (6.5 feet) of the tank.

### Heating Coils

Heating coils left in position during cargo tank blasting and coating should be masked with suitable material. After blasting, the masking should be removed and the coils cleaned (in order to avoid contamination caused by grit falling onto the freshly applied paint on the tank surfaces).

Coils should then be rewrapped prior to the start of tank coating application. Whenever possible, heating coil brackets should be of stainless steel.

### Cleaning

The bulk of spent abrasive and dust must be removed prior to the initial blasting inspection.

Following acceptance of the preparation standard, all remaining traces of abrasive and dust should be removed from all areas using industrial vacuum cleaners fitted with brushes, or by other suitable methods agreed by the International Paint Representative on site.

## Procedures

There are many different procedures for gritblasting and applying coatings in a cargo tank. The following four procedures represent the most commonly used and accepted. Other procedures may be acceptable but should be discussed and agreed with International Paint prior to implementation.

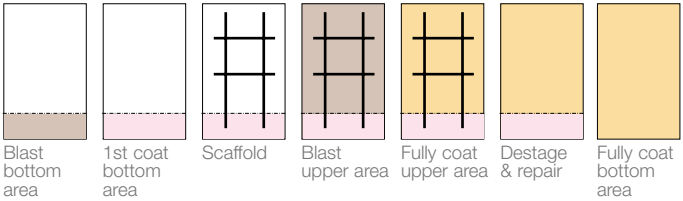
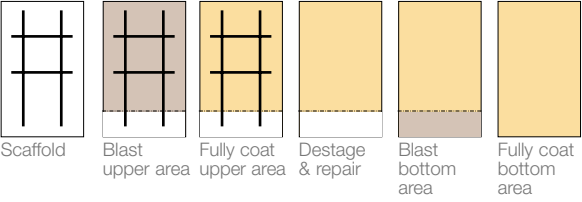
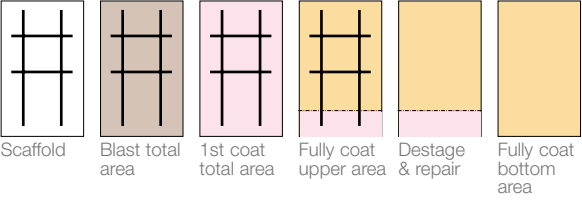
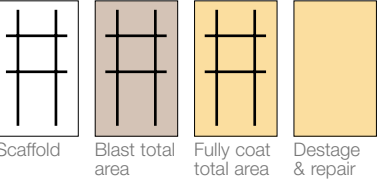
<b>A</b>	 <p>Blast bottom area    1st coat bottom area    Scaffold    Blast upper area    Fully coat upper area    Destage &amp; repair    Fully coat bottom area</p>	<p><b>Advantages</b></p> <ul style="list-style-type: none"> <li>Unrestricted access for bottom blasting</li> <li>Easier cleaning of upper area after bottom blasting</li> <li>No overblast/ricochet damage on fully coated upper area</li> </ul> <p><b>Disadvantages</b></p> <ul style="list-style-type: none"> <li>Long overcoating time for primer or first coat required</li> <li>Overlap requires careful preparation</li> <li>Careful cleaning of bottom required</li> </ul>
<b>B</b>	 <p>Scaffold    Blast upper area    Fully coat upper area    Destage &amp; repair    Blast bottom area    Fully coat bottom area</p>	<p><b>Advantages</b></p> <ul style="list-style-type: none"> <li>No holding primer required</li> <li>No potential overcoating problems</li> </ul> <p><b>Disadvantages</b></p> <ul style="list-style-type: none"> <li>Overblast/ricochet damage on fully coated upper area</li> <li>Overlap requires careful preparation</li> <li>Cleaning of uppers after bottom blasting can be difficult without staging</li> </ul>
<b>C</b>	 <p>Scaffold    Blast total area    1st coat total area    Fully coat upper area    Destage &amp; repair    Fully coat bottom area</p>	<p><b>Advantages</b></p> <ul style="list-style-type: none"> <li>Continuous blasting avoids overblast/ricochet damage on coated areas</li> <li>Easier cleaning</li> </ul> <p><b>Disadvantages</b></p> <ul style="list-style-type: none"> <li>Restricted access for bottom blasting</li> <li>Long overcoating time for primer or first coat required</li> <li>Scaffold contact points on bottom need careful preparation</li> <li>Overlap requires careful preparation</li> <li>High levels of dehumidification required</li> </ul>
<b>D</b>	 <p>Scaffold    Blast total area    Fully coat total area    Destage &amp; repair</p>	<p><b>Advantages</b></p> <ul style="list-style-type: none"> <li>Continuous blasting avoids overblast/ricochet damage on coated areas</li> <li>Easier cleaning</li> </ul> <p><b>Disadvantages</b></p> <ul style="list-style-type: none"> <li>Possible dry spray on bottom when coating upper area</li> <li>Scaffold contact points on bottom need careful preparation</li> <li>Bottoms likely to be damaged whilst destaging</li> </ul>

When preparing surfaces by other means, all traces of debris should also be removed by appropriate methods.

Before application of the coating, the amount of residual salt on the prepared steel surface should be measured by the Bresle patch method (ISO 8502-6: 1995) or similar. If the salt contamination level is above the maximum that is permissible for the particular product being used,† further fresh water washing, blasting and cleaning will be required.

#### **Coatings Application**

All products must be applied in line with detailed advice provided by International Paint on can (container) labels, Product (Technical) Data Sheets and Material Safety Data Sheets.

The coating system must be applied in accordance with the agreed specification. All coatings must be applied by airless spray, except for stripe coats where brush or roller is recommended.

Airless spray equipment must be in good working order and be capable of performing to the output requirements defined in the Product (Technical) Data Sheets.

#### **Air Pressure**

Available air pressure and capacity for spray equipment must be at least 5.5kg/cm<sup>2</sup> and 1.4m<sup>3</sup>/min (80 p.s.i. and 50 cfm).

#### **Pump Ratios**

It is recommended that airless spray pump ratios of 40:1 or greater should be used.

#### **Tip Size**

Airless spray tips must be the size stipulated on the Product (Technical) Data Sheet or as agreed with the International Paint Representative on site. Tips must not be in a worn condition.

#### **Mixing**

Efficient mechanical stirrers or power agitators should be used to ensure complete mixing of the coating before, and during application.

#### **Dehumidification**

Dehumidification equipment, when needed, must be of adequate capacity to maintain the environmental conditions required in the tank. Additionally, in order to prevent condensation, the steel temperature must always be at least 5°F (3°C) above the dew point.

Coatings may only be applied to surfaces which have been maintained in a dry condition with the steel temperature at least 5°F (3°C) above the dew point for more than one hour. The surfaces must be visibly dry and clean at the time of application. This condition must be maintained until the coating is cured.

Coating work must only be undertaken under acceptable environmental conditions in the tank, as advised by the International Paint Representative on site.

Provision should be made for 24 hour surveillance of equipment.

“For optimum performance of cargo tank coatings, close control of dry film thickness is essential.”

#### **Dry Film Thickness**

For optimum performance of cargo tank coatings, close control of dry film thickness is essential. Over application may result in slow cure and solvent entrapment, whereas under application can lead to reduced in service performance.

Maximum and minimum dry film thicknesses, as detailed in the application procedures for the particular product being used, must be strictly adhered to. Consult International Paint for details.



*Dry film thickness measurement.*

† Consult International Paint for details.

## Stripe Coats

Stripe coating is an essential part of good painting practice in cargo tanks. Typical areas where stripe coats should be applied include:

- backs of stiffeners
- cut outs i.e. scallops, etc
- welds
- areas of difficult access (corners etc)
- ladders and hand rails
- areas of properly prepared pitting

In general, stripe coats should be applied by brush or roller depending on the items concerned. In exceptional circumstances it may be acceptable to apply a stripe coat to the backs of stiffeners by narrow-angle airless spray.

The use of spray applied stripe coats however, should be discussed and agreed with the International Paint Representative on site.



*Inspection of stripe coats.*

## Ventilation Layout

During coatings application, forced ventilation/extraction (via flexible trunking) should be in place and remain operational for at least 48 hours after completion of the coating application.

Coating solvents are generally heavier than air, and therefore the ventilation/extraction system and trunking must be capable of extending to the lower most parts of the tank. Trunking should be arranged so that continuous air movement occurs in all areas and no dead spaces exist.

Ventilation must be arranged so as not to re-introduce abrasive dust and solvent vapour into the tanks.

Equipment should be electrically safe; it should be designed so that sparks or hot surfaces/bearings are not in contact with solvent laden air. Fan motors must be outside the extraction airstream.

*Key areas for stripe coat application.*

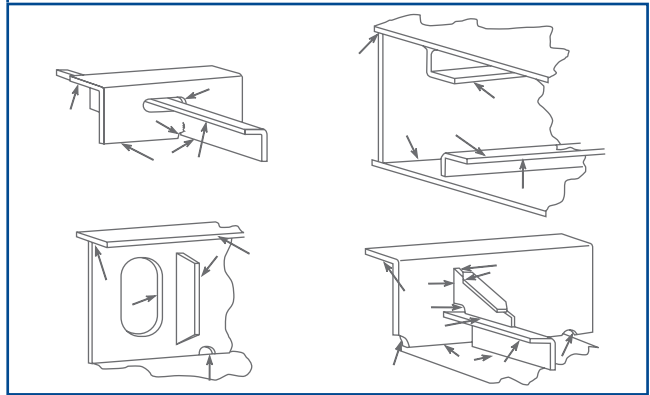

## Safety

The ventilation/extraction system must prevent the solvent vapour concentration in the tank from exceeding 10% of the lower explosive limit (or less than this if required by local regulations).

Ventilation/extraction at this level, or at least 5 complete air changes per hour is required. Provision must be made for 24 hour surveillance of ventilation/extraction equipment.

Ventilation/extraction should be maintained for at least 48 hours after completion of coatings application, otherwise release of solvent from the coatings during drying/curing may create an explosive atmosphere.

## Heating

If heating is necessary to satisfy the painting or curing specification it should be by means of a heat exchange system, i.e. air admitted to the tank should not pass directly through a combustion chamber.

Provision must be made for 24 hour surveillance of equipment.

## Lighting

Lighting used during surface preparation and painting must be electrically protected (Ex) so as not to ignite any solvent vapour. The lighting should provide suitable illumination for all work and be sufficiently powerful (mains supplied) at all times.

## Seawater Test

Following the appropriate curing period the tank should be subjected to a seawater test to highlight pinholes, areas of mechanical damage etc., which have not been identified by normal visual inspection. This may be carried out either by:

- a) Full seawater ballasting of the tank for at least 24 hours.
- b) Seawater recirculation using the tank washing system for at least 48 hours.

Following seawater testing, the tank should be thoroughly washed down with fresh water, dried and any defective areas repaired in accordance with the recommendations of the International Paint Representative on site.

## Repairs

These procedures are recommended for the repair of damages either at the initial coating stage or during cargo tank maintenance.

The procedure recommended will depend upon the type and extent of repair involved.

### Major Repairs

Where major repairs are required, work should be carried out in accordance with all the previous sections of these working procedures.

### Minor Repairs

These are repairs to areas damaged, either at the initial coating stage, (e.g. by destaging) or during the in service period (e.g. cargo-induced damages, subsequent corrosion etc).

The principle requirements are:

- Fresh water wash to remove all salt contamination and any remaining cargo residues.
- Degrease according to SSPC-SP1 solvent cleaning to remove oil, dirt etc.
- The area to be repaired must be dry.
- Remove any corrosion by means of either:
  - vacuum blasting
  - mechanical cleaning i.e. disc sander or grinder.
- Abrade coated area immediately surrounding repair to provide a key for subsequent paint overlap adhesion.
- Apply the paint system in accordance with the agreed specification. If small areas are involved and application is by brush (or roller), several coats may be required to achieve the correct dry film thickness.
- All products must be applied in line with detailed advice provided by International Paint on can (container) labels, Product (Technical) Data Sheets and Material Safety Data Sheets.
- Consult International Paint for details on minimum cure times prior to cargo loading/service entry following coating repairs.

## Health and Safety

Most cargo tank coatings contain volatile, flammable organic solvents which can form explosive mixtures with air. Additionally, cargo tank coating operations require the use of suitable personal protection equipment to protect against potential health hazards. Appropriate precautions must be taken whilst carrying out surface preparation and applying coatings in the confines of a ship's cargo tank.

Detailed attention must be given to the following points:

- Danger of explosion or fire. (Ensure that the tanks and surrounding areas are flame and spark-free.)
- Provision of adequate ventilation/extraction.
- Provision of suitable breathing equipment for workers.
- Prevention of skin irritation.
- Protection of skin, eyes, ears etc.
- Ensure that suitable protective clothing and equipment is available and worn.
- Rescue equipment e.g. independent air supply (air cylinder) to be available for use in emergencies.
- Use only coatings that have been specifically formulated for use in cargo tanks.

Consult International Paint for detailed Health and Safety advice.

*Inspection of cargo tank following full coating refurbishment.*



*Cargo tank: Completed newbuilding application.*

International Paint Ltd is part of Akzo Nobel, the Netherlands based company serving customers throughout the world with healthcare products, coatings and chemicals. Consolidated sales for 2003 totalled EUR 13 billion. Akzo Nobel currently employs approximately 64,300 people in more than 80 countries.



## Worldwide Operations

Argentina	France	New Zealand	South Africa
Australia	Germany	Northern Ireland	South Korea
Bahrain	Greece	Norway	Spain
Belgium	Hong Kong	Pakistan	Sri Lanka
Brazil	Iceland	Panama	Sweden
Bulgaria	India	Papua New Guinea	Taiwan
Canada	Indonesia	Peoples Republic of China	Thailand
Chile	Iran	Peru	Turkey
Colombia	Italy	Philippines	U.S.A.
Croatia	Japan	Poland	Ukraine
Cuba	Kuwait	Portugal	United Arab Emirates
Cyprus	Latvia	Qatar	United Kingdom
Denmark	Lithuania	Republic of Ireland	Uruguay
Ecuador	Luxembourg	Romania	Venezuela
Egypt	Malaysia	Russia	Vietnam
Estonia	Malta	Saudi Arabia	Western Samoa
Fiji	Mexico	Singapore	Yemen
Finland	Netherlands	Slovenia	

### Important Notes:

All representations and statements concerning the product(s) in this brochure are accurate to the best of our knowledge. Statements made in this brochure are advisory only and are not intended to be specific recommendations or warranties of any product, combination of products or fitness for any particular purpose. To the extent permitted by law, we do not accept any liability to any person for any loss or damage (direct or indirect) that may arise from any use of or reliance on any of the methods or information contained in this brochure for any purpose.

Unless otherwise agreed in writing, all products supplied and technical advice or recommendations given are subject to the Conditions of Sale of our supplying company. Any warranties, if given, are contained in those standard Conditions of Sale and are the only ones made with respect to any products we sell to you or advice or recommendations we give to you.

For each of our products the relevant Product Data Sheet, Material Safety Data Sheet and package labelling comprise an integral information system about the product in question. Copies of our Product Data Sheets and Material Safety Data Sheets are available on request or from our website: [www.international-marine.com](http://www.international-marine.com)

✖, International and all products mentioned in this brochure are trademarks of or are licensed to Akzo Nobel.

© Akzo Nobel, 2004

International Paint Ltd, Stoneygate Lane, Felling, Gateshead NE10 0JY.  
Tel: +44 (0)191 402 2775 Fax: +44 (0)191 401 2320

[www.international-marine.com](http://www.international-marine.com)

